

■ Dimensions Drawing

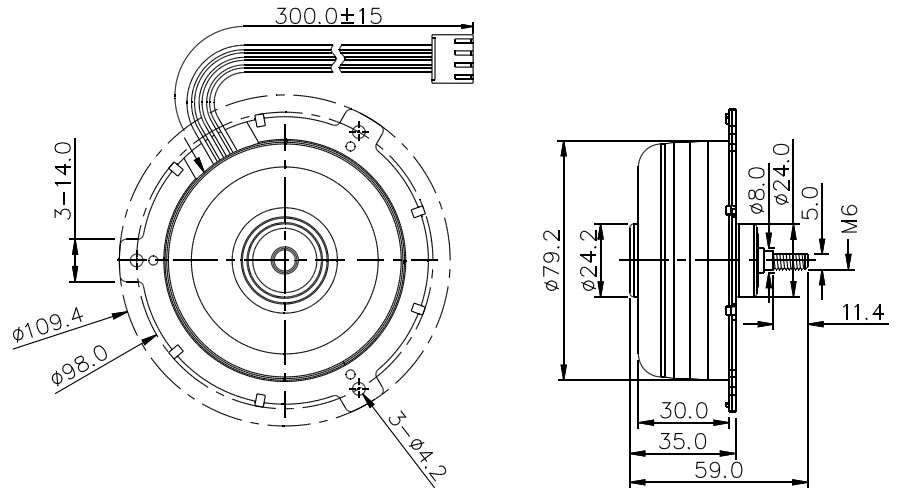

Unit:mm

General Specification

Steel Packed Type

Inner Rotor Motor

Plastic Ferrite Rotor

UL Type Lead Wire

Operation Temperature: -10°C~60°C
35%~85%RH

Storage Temperature : -10°C~70°C、
35%~85%RH

■ CONNECTOR PIN ASSIGNMENT

- Red: Motor Driver Power, Vm(36VDC)
- Yellow: Control IC Power, Vcc(12VDC)
- White: Frequency Signal Output(2 pulses/rev.)
- Black: GND

Model Number	Voltage		No Load			Rated Load			
	Operating (VDC)	Rated (VDC)	Speed (rpm)	Current (A)	Noise (dBA)	Speed (rpm)	Current (A)	Torque (mN.m)	Power (W)
RMH8032B3	5~40	36	6500	0.25	42	3800	1.35	60	24

■ TORQUE-SPEED/CURRENT/EFFICIENCY CHARACTERISTICS

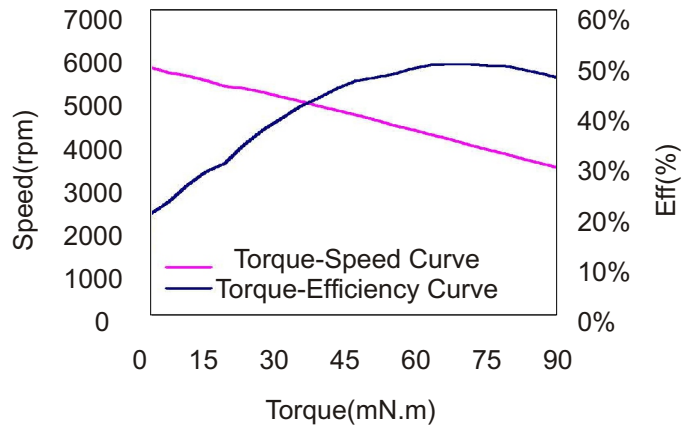
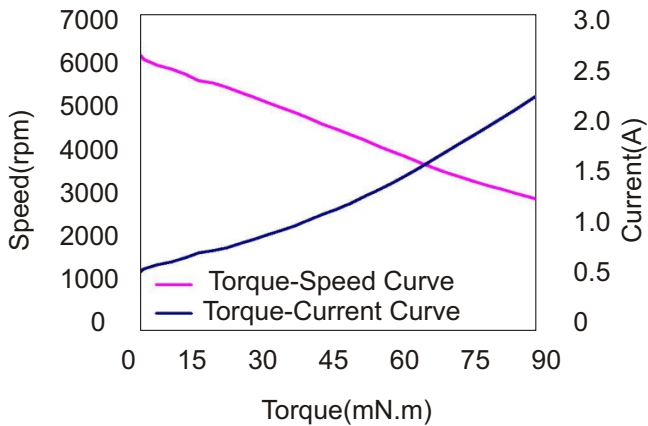

Notes: ©All readings are typical values at rated voltage.
©Specifications subjected to change without prior notice.